



DOI: 10.31643/2022/6445.36

## Analysis of Existing Technologies for Depletion of Dump Slags of Autogenous Melting

<sup>1</sup> Kenzhaliyev B.K., <sup>1</sup> Kvyatkovskiy S.A., <sup>1\*</sup> Dyussebekova M.A., <sup>1</sup> Semenova A.S., <sup>2</sup> Nurhadiyanto D.

<sup>1</sup> "Institute of Metallurgy and Ore Beneficiation" JSC, Satbayev University, Almaty, Kazakhstan

<sup>2</sup> Faculty of Engineering, Universitas Negeri Yogyakarta, Indonesia

\* Corresponding author email: m.dyussebekova@satbayev.university

### ABSTRACT

Pyro-metallurgy of copper production is characterized by the output of copper slag, which is regarded as a kind of solid waste. Moreover, this slag is identified as hazardous because it contains impurities, like Pb, As, and Cu. Obtaining dump slags in autogenous processes does not always meet the requirements of effective technologies, most often slags contain more than 1.0% of copper and need to be depleted. This work is presented a brief analysis of existing technologies used for copper slag depletion. The analysis of the existing technologies for the depletion of autogenous smelting dump slags showed that the most promising option seems to be the depletion of copper slags in one PV unit since by improving the process itself, by changing the unit design, it is possible to achieve technologically complete production of matte and dump slag with low copper content. There were proposed two technologies of improvement: electro-heating of slag siphon using the graphite electrodes and depletion process in two-zone PV furnace.

**Keywords:** Copper slag, reduction treatment, depletion, slag siphon, two-zone Vanyukov furnace.

Received: March 25, 2022  
Peer-reviewed: April 09, 2022  
Accepted: April 28, 2022

	<b>Information about authors:</b>
<b>Kenzhaliyev Bagdaulet Kenzhaliyevich</b>	Doctor of Technical Sciences, Professor, General Director-Chairman of the Management Board of the JSC "Institute of Metallurgy and Ore Beneficiation", Almaty, Kazakhstan. Email: bagdaulet_k@satbayev.university; ORCID ID: 0000-0003-1474-8354
<b>Kvyatkovskiy Sergey Arkad'yevich</b>	Doctor of Technical Sciences., Chief of Laboratory, JSC "Institute of Metallurgy and Ore Beneficiation", Almaty, Kazakhstan. Email: s.kvyatkovskiy@satbayev.university; ORCID ID: 0000-0002-9686-8642
<b>Dyussebekova Maral Adel'bekovna</b>	Junior researcher, JSC "Institute of Metallurgy and Ore Beneficiation", Almaty, Kazakhstan. Email: m.dyussebekova@satbayev.university; ORCID ID: 0000-0002-4359-9784
<b>Semenova Anastasiya Sergeevna</b>	Master of Engineering Science, Leading Engineer, "Institute of Metallurgy and Ore Beneficiation", Almaty, Kazakhstan. ORCID ID: 0000-0003-4054-8268. E-mail: a.semenova@satbayev.university
<b>Didik Nurhadiyanto</b>	Doctor of Engineering, Lecturer, Faculty of Engineering, Universitas Negeri Yogyakarta, Indonesia. E-mail: didiknur@uny.ac.id; ORCID ID: 0000-0003-0643-0776.

### Introduction

Comparative analysis of technical indicators of autogenous processes indicates that slags require several measures to deplete them. For example, in the Norand process, the copper content in slags can reach 15%, KFP - 1.2%, KVP - 1-1.5%, Ausmelt - 0.8-1.0%, Mitsubishi - 0.5%, PV - 0.5-0.6%. The best indicators for dump slags are possible in the Mitsubishi and PV processes, however, a significant deterioration in the composition of concentrates in recent years leads to a violation of the technology and the production of copper-rich slags [[1], [2], [3], [4], [5], [6], [7]]. Slag depletion technologies have two main directions: the improvement of matte smelting itself with the production of dump slags and the use of separate units that allow slag

depletion (for example, an electric furnace with several high-power units). The first option is expedient, promising, and economically viable. Improvement of the melting process on matte and the design of the furnace will make it possible to achieve the most significant results in slag depletion [[8], [9]].

Carrying out autogenous smelting of copper raw materials is closely related to the solution of slag depletion issues, which involves the implementation of the following conditions: obtaining a minimum amount of slag with low copper content, while the maximum should be fluidity, slag surface tension, minimum slag density, optimal silicon dioxide content, optimal temperature conditions for the separation of matte and slag [[10], [11], [12]]. Temperature conditions, maintenance of thermal

balance due to oxidation of iron sulfides, control of moisture, and silicon oxide in concentrates are of exceptional importance for autogenous smelting. In a certain situation, to maintain the heat balance of the furnace, it is possible, and sometimes necessary, to use additional fuel, for example, natural gas, fuel oil, or coal [[13], [14]].

To compensate for the unsatisfactory heat balance, the insufficient temperature of the melt at the outlet of the furnace, and additional precipitation of the matte phase from the slag melt, it is very important to improve the operation of slag electric mixers on PV furnaces. Analysis of the influence of various factors on the PV process showed that all of them are of decisive importance for the efficient course of the smelting process, the main of which are indicators for the composition of dump slags, which determine the technical and economic characteristics of the entire technology [[14], [15]].

### Method

The samples of the slags were obtained from the Vanyukov furnace in Balkhash Copper-Smelting Plant. These samples were analyzed by chemical and X-ray fluorescence analysis. X-ray fluorescence multi-element automated analysis was carried out on a wave-dispersive combined spectrometer Axios.

To simulate the oxidation zone of a two-zone PV furnace the slag was heated to a temperature of 1300 °C in the presence of a reducing agent, then the melt was kept for 1 hour. The consumption of coal was calculated as 2.5 g per 100 g of slag.

### Results and discussion

#### Analysis of existing technologies for copper slag depletion

Depletion of slags when using a technology separate from smelting is possible using various processes such as pyro, hydro, and a combination of pyro-hydrometallurgical methods for metal recovery from copper slag [16]. One of the most promising is the reduction methods using electrothermal furnaces with various methods of supplying the reducing agent. Solid (coke, coal) and gaseous (coal-air mixture, natural and generator gas) substances are used as reducing agents. In world practice, separate or combined with a melting unit electrothermal furnaces, furnaces with a reducing bubbling using coal, natural, or generator gas are most often used [17]. There are known

examples of slag depletion in the presence of pyrite, pyrrhotite, calcium sulfide, and cast iron [18]. It is possible to use turbulent mixing of a superheated slag melt for purification from copper with the introduction of  $\text{CaC}_2$  into the process as a reducing agent [19]. The effect of an electric field on a slag melt was studied in [20]. It was found that there is a 3-fold increase in the deposition rate of copper drops with a diameter of 5 mm. It is noted that with an increase in the size of the metalized droplet or with an increase in the  $\text{Cu}_2\text{O}$  content in the slag, the effect of the electric field decreases.

Methods of depletion of slags from copper production using sulfide reagents are seldom used due to environmental pollution with sulfur dioxide and to reduce the number of waste slags. Environmentally friendly methods are hydrometallurgical, in particular, the most common and industrially implemented is flotation, which includes the preparation of slag by crushing and grinding in several stages, flotation together with ore material (or separate for slag) to obtain sulfide copper concentrate suitable for smelting on matte [21]. This method assumes the availability of the necessary flotation capacity at the concentrator. The disadvantages of such technologies are the relatively low extraction of copper into concentrate and the low quality of these concentrates themselves. Moreover, copper slag wastes after floatation treatment, still contain heavy metals with hazardous properties posing environmental risks, so they needed further utilization [22].

A method has been developed for the depletion of copper slag by leaching using various solvents such as sulfuric acid, hydrochloric acid, ammonia, cyanide, etc. [[23], [24], [25], [26]]. An intensification of the process of leaching of copper slags with the addition of hydrogen peroxide under pressure, as well as with the use of chlorine, has been proposed [[27], [28]]. Improvement of matte smelting itself with the production of dump is more expedient, promising, and economically viable and an additional increase in the slag settling zone, in which depletion occurs with the introduction of a reducing agent, is the most promising direction.

#### Improvement of slag siphon

The slag siphon structurally is a continuation of the melting zone of the PV, adjacent to the outer part of the slag partition, and in solving the problem of depletion of the slag PV and obtaining the waste slag is of great importance. Improving the operation of the PV slag siphon is expected to take several

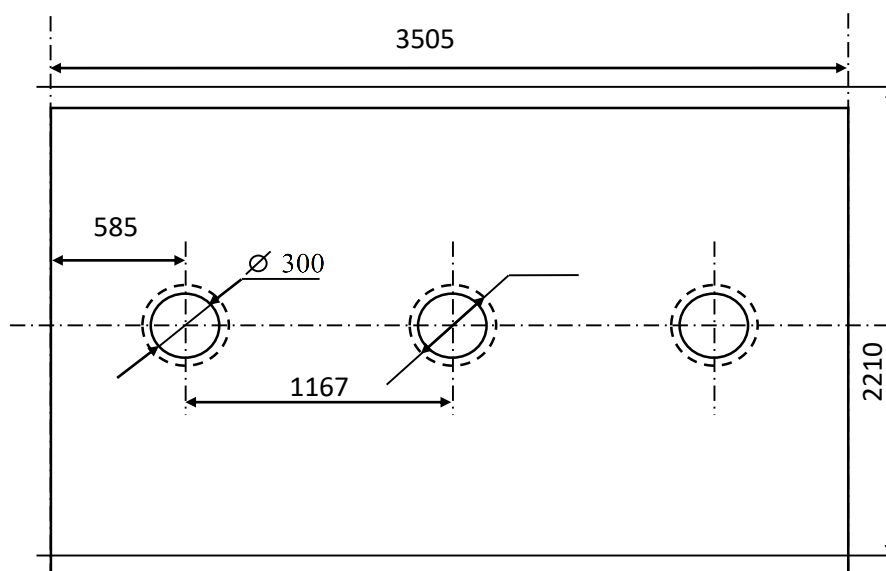

Picture 1 – Layout of electrodes in a slag siphon

measures that will affect the processing of copper sulfide concentrates, improve the technical and economic indicators of the process, increase copper recovery, significantly reduce its losses with slag, and eliminate disturbances in the normal operation of PV furnaces. The stable operation of the slag siphon of the PV furnace is often disturbed by deposition processes, which is also facilitated by changes in the composition of the charge, for example, an increase in the content of zinc in concentrates. The continuous discharge of slag from the PV furnace into the electric mixer prevents the formation of build-ups, which are the result of the absence of horizontal movement of the melt and local peroxidation of the melt in the bubbling zones. In the slag siphon, it is necessary to create a regime of free movement of the melt, the possibility of sedimentation of copper sulfide particles, which is possible at a certain temperature regime, the creation of a reducing atmosphere, and the optimal composition of the slag.

A variant is proposed using three graphite electrodes with a diameter of 300 mm and a transformer similar to that used for a slag mixer. The use of electric heating of the slag siphon will allow, when the temperature of the melt in the slag siphon reaches at least 1300 °C, to ensure sufficiently

complete separation of slag and matte. The electrodes in the siphon will operate at a relatively constant level of the slag melt with a uniform flow of slag through the slag siphon, which will provide optimal conditions for additional heating of the slag and the most complete separation of the matte phase from the slag and prevention of build-up in the siphon (Picture 1).

Additional heating of the slag in the slag siphon will reduce the power consumption in the slag mixer to maintain the melt temperature at least 1300 °C. The use of graphite electrodes with a diameter of 300 mm will allow for maintaining the existing width of the slag siphon.

#### ***Depletion in a 2-zone furnace***

This process would be possible by dividing the reaction zone of the furnace into two zones oxidizing and reducing using a water-cooled partition. Slag samples were obtained from the Vanyukov furnace and their content is shown in Table 1.

Activated carbon was used as a reducing agent with the following content wt. %: 74.3 C, 0.16 S, 0.025 P, 1.12 Fe, 0.93 SiO<sub>2</sub>, 1.56 Al<sub>2</sub>O<sub>3</sub>; melting temperature was – 1300 °C. The reduction treatment was carried out on a laboratory scale.

The slag was heated to a temperature of 1300 °C in the presence of a reducing agent, then the melt

**Table 1** - Content of main components in slag before/after reduction treatment

№ of test	Slag content, %					
	Before treatment			After treatment		
	Cu	SiO <sub>2</sub>	Fe <sub>3</sub> O <sub>4</sub>	Cu	SiO <sub>2</sub>	Fe <sub>3</sub> O <sub>4</sub>
11	0.93	32.05	7.80	0.43	33.1	2.5
12	0.97	31.90	7.90	0.47	32.9	2.6
13	1.033	31.30	7.95	0.50	32.9	2.6

was kept for 1 hour. The consumption of coal was calculated as 2.5 g per 100 g of slag. At the end of the reduction process - slag and the bottom phase were obtained. The bottom phase had a similar composition to the matte obtained during smelting in a PV furnace.

Table 1 also shows the results of reduction processing, and it's seen that during the melting process the destruction of magnetite took place, its content had dropped by 5.3-6.5 % from 7.8 -7.95% to 2.5-2.6%, and this consequently had a positive effect on prevention of copper losses with slags. The presented results of analysis of slag samples after interaction with activated carbon indicate a decrease in copper content in the range of 0.43-0.50%, in comparison with its content in slags before reduction treatment in the range of 0.93-1.03%. Such a decrease in the copper content is associated with the process of destruction of magnetite, and the transition of iron oxides to fayalite.

### Conclusion

All the proposed solutions for slag depletion, for the implementation of which industrial installations of operating units are required, occupying vast territories, consuming significant material and energy resources, are economically and ecologically unprofitable. The most promising option seems to

be the option of depletion of copper slag in one PV unit since by improving the process itself, by changing the unit design, it is possible to achieve a technologically complete production of matte and dump slag with low copper content. The use of graphite electrodes for additional heating of the slag in the slag siphon will reduce the power consumption in the electrical mixer and at the same time will allow maintaining the existing width of the slag siphon. On the other hand, in comparison with similar developments, the proposed technology for melting copper sulfide concentrates in a two-zone PV furnace will make it possible to obtain slags with a copper content of 0.7% or less, with minimal costs for equipment reconstruction.

### Conflict of interests

On behalf of all authors, the correspondent author declares that there is no conflict of interest.

### Acknowledgments

This research was funded by the Science Committee of the Ministry of Education and Science of the Republic of Kazakhstan (Grant No. AP08855511).

**Cite this article as:** Kenzhaliyev BK, Kvyatkovskiy SA, Dyussebekova MA, Semenova AS, Nurhadiyanto D. Analysis of Existing Technologies for Depletion of Dump Slags of Autogenous Melting. Kompleksnoe Ispol'zovanie Mineral'nogo Syr'a = Complex Use of Mineral Resources 2022;323(4):23-29. <https://doi.org/10.31643/2022/6445.36>

## Автогенді балқыту қалдықтарын қожды сарқудың қолданыстағы технологияларын талдау

<sup>1</sup> Кенжалиев Б.К., <sup>1</sup> Квятковский С.А., <sup>1</sup> Дюсебекова М.А., <sup>1</sup> Семенова А.С., <sup>2</sup> Нурхадиянто Д.

<sup>1</sup> «Металлургия және кен байыту институты» АҚ, Сәтбаев университеті, Алматы, Қазақстан

<sup>2</sup> Инженерия факультеті, Джокьякарта мемлекеттік университеті, Индонезия

Мақала келді: 25 наурыз 2022  
Сараптамадан өтті: 09 сәуір 2022  
Қабылданды: 28 сәуір 2022

**ТҮЙІНДЕМЕ**

Мыс өндірісінің пирометаллургиясы қатты қалдықтарға жататын мыс қождарының бөлінуімен сипатталады. Сонымен қатар, бұл қож қауіпті болып саналады, өйткені оның құрамында Pb, As және Cu сияқты қоспалар бар. Автогендік процестерде үйінді қождарын алу әрдайым тиімді технологиялардың талаптарына сәйкес келмейді, көбінесе қождар құрамында 1,0% - дан астам мыс бар және оларды жұтаңдату қажет. Бұл жұмыста мыс қождарын азайту үшін қолданылатын қолданыстағы технологияларға қысқаша талдау берілген. Автогенді балқытудың үйінді қождарын жұтаңдату қолданыстағы технологияларын талдау нәтижесінде ең перспективалы нұсқа ПВ-ның бір агрегатында мыс қождарын жұтаңдату екендігі анықталды, өйткені процестің өзін жақсарту, қондырғының дизайнын өзгерту арқылы технологиялық тұрғыдан аяқталған, штейн мен мыстың мөлшері аз болатын үйіндіні өндіруге қол жеткізуге болады. Жұмыста жетілдірілген екі технология ұсынылған, олар: қож сифонын графит электродтар арқылы электр тогымен жылыту және екі аймақтық ПВ пешінде жұтаңдату процесі.

**Түйін сөздер:** Мыс қожы, қалпына келтіру, сарқылу, қож сифоны, Ванюковтың екі аймақтық пеші.

	<b>Авторлар туралы ақпарат:</b>
<b>Кенжалиев Багдаулет Кенжалиевич</b>	Т.ф.д., «Металлургия және кен байыту институты» АҚ - ның бас директоры, Алматы, Қазақстан. Email: bagdaulet_k@satbayev.university; ORCID ID: 0000-0003-1474-8354
<b>Квятковский Сергей Аркадьевич</b>	Т.ф.д., «Металлургия және кен байыту институты» АҚ, зертхана меңгерушісі, Алматы, Қазақстан. Email: s.kvyatkovskiy@satbayev.university; ORCID ID: 0000-0002-9686-8642
<b>Дюсебекова Марал Адельбековна</b>	Т.ф. магистрі, «Металлургия және кен байыту институты» АҚ, кіші ғылыми қызметкер, Алматы, Қазақстан. Email: m.dyussebekova@satbayev.university; ORCID ID: 0000-0002-4359-9784
<b>Семенова Анастасия Сергеевна</b>	Т.ф. магистрі, «Металлургия және кен байыту институты» АҚ, жетекші инженер, Алматы, Қазақстан. E-mail: a.semenova@satbayev.university; ORCID ID: 0000-0003-4054-8268
<b>Дидик Нурхадиянто</b>	И.ф. докторы, Лектор, Инженерия факультеті, Джокьякарта мемлекеттік университеті, Индонезия. E-mail: didiknur@uny.ac.id; ORCID ID:0000-0003-0643-0776

## Анализ существующих технологий обеднения отвальных шлаков автогенной плавки

<sup>1</sup> Кенжалиев Б.К., <sup>1</sup> Квятковский С.А., <sup>1</sup> Дюсебекова М.А., <sup>1</sup> Семенова А.С., <sup>2</sup> Нурхадиянто Д.

<sup>1</sup> АО «Институт металлургии и обогащения», Satbayev University, Алматы, Казахстан

<sup>2</sup> Инженерный факультет, Государственный университет Джокьякарты, Индонезия

Поступила: 25 марта 2022  
Рецензирование: 09 апреля 2022  
Принята в печать: 28 апреля 2022

**АННОТАЦИЯ**

Пирометаллургия медного производства характеризуется выходом медных шлаков, которые относят к твердым отходам. Кроме того, этот шлак считается опасным, так как содержит такие примеси, как Pb, As и Cu. Получение отвальных шлаков в автогенных процессах не всегда соответствует требованиям эффективных технологий, чаще всего шлаки содержат более 1,0% меди и нуждаются в обеднении. В данной работе представлен краткий анализ существующих технологий, используемых для обеднения медных шлаков. Анализ существующих технологий обеднения отвальных шлаков автогенной плавки показал, что наиболее перспективным вариантом является обеднение медных шлаков в одном агрегате ПВ, так как путем совершенствования самого процесса, изменением конструкции агрегата можно добиться технологически завершеного производства штейна и отвального шлака с низким содержанием меди. Предложены две технологии совершенствования: электрообогрев шлакового сифона графитовыми электродами и процесс обеднения в двухзонной печи ПВ.

**Ключевые слова:** Медный шлак, восстановительная обработка, обеднение, шлаковый сифон, двухзонная печь Ванюкова.

	<b>Информация об авторах:</b>
<b>Кенжалиев Багдаулет Кенжалиевич</b>	Д.т.н., Генеральный директор-Председатель Правления АО «Институт Металлургии и Обогащения», Алматы, Казахстан. Email: bagdaulet_k@satbayev.university; ORCID ID: 0000-0003-1474-8354
<b>Квятковский Сергей Аркадьевич</b>	Д.т.н., заведующий лабораторией, АО «Институт Металлургии и Обогащения», Алматы, Казахстан. Email: s.kvyatkovskiy@satbayev.university; ORCID ID: 0000-0002-9686-8642



<b>Дюсебекова Марал Адельбековна</b>	М.н.с., АО «Институт Металлургии и Обогащения», Алматы, Казахстан. Email: <a href="mailto:m.dyussebekova@satbayev.university">m.dyussebekova@satbayev.university</a> ; ORCID ID: 0000-0002-4359-9784
<b>Семенова Анастасия Сергеевна</b>	Магистр технических наук, ведущий инженер, АО «Институт металлургии и Обогащения», Алматы, Казахстан. E-mail: <a href="mailto:a.semenova@satbayev.university">a.semenova@satbayev.university</a> ; ORCID ID: 0000-0003-4054-8268
<b>Дидик Нурхадиянто</b>	Доктор инженерных наук, Лектор, Инженерный факультет, Государственный университет Джокьякарты, Индонезия. E-mail: <a href="mailto:didiknur@uny.ac.id">didiknur@uny.ac.id</a> ; ORCID ID: 0000-0003-0643-0776

## References

- [1] Altushkin IA, Korol' YUA, Golov AN. Innovacii v metallurgii medi na primere realizacii proekta rekonstrukcii ZAO «Karabashmed». CHast' I. Vyor osnovnogo plavil'nogo agregata [Innovations in copper metallurgy on the example of the implementation of the reconstruction project of CJSC Karabashmed. Part 1. Selection of the main melting unit]. *Cvetnyemetally= Non-ferrous metals* 2012;8: 25-34. (in Russ.).
- [2] Guo Z, Pan J, Zhu D, Zhang F. Innovative methodology for comprehensive and harmless utilization of waste copper slag via selective reduction-magnetic separation process. *Journal of Cleaner Production*. 2018;187:910-922. <http://doi.org/10.1016/j.jclepro.2018.03.264>
- [3] Sarfo P, Wyss G, Ma G, Das A, Young C. Carbothermal reduction of copper smelter slag for recycling into pig iron and glass. *Minerals Engineering*. 2017;107:8-19. <http://doi.org/10.1016/j.mineng.2017.02.006>
- [4] Ryabko AG, Cemekhman LSH. Razvitie avtogennoy processov v metallurgii medi i nikelya [Development of autogenous processes in copper and nickel metallurgy]. *Cvetnye metally=Non-ferrous metals* 2003;7:58-63. (in Russ.).
- [5] Kozhahmetov SM, Kvyatkovskij SA, Ospanov EA, Bekenov MS, Kamirdinov GSH. Perspektivy osvoeniya besflyusovoy avtogennoj plavki smesi vysokokremnezemistyh i zhelezistyh mednyh koncentratov na Balhashskom medeplavil'nom zavode [Prospects for the development of flux-free autogenous smelting of a mixture of high-silica and ferruginous copper concentrates at the Balkhash copper smelter]. *Cvetnye metally = Non-ferrous metals* 2010;4:63-65. (in Russ.).
- [6] Komkov AA, Byistrov VP, Rogachev MB. Raspredelenie primesej pri plavke mednogo sul'fidnogo syr'ya v pechi Vanyukova [The distribution of impurities during the smelting of copper sulfide raw materials in the Vanyukov furnace]. *Cvetnye metally = Non-ferrous metals* 2006;5:17-25. (in Russ.).
- [7] Dyussebekova M, Kenzhaliyev B, Kvyatkovskiy S, Sit'ko E, Nurkhadianto D. The main reasons for increased copper losses with slags from Vanyukov Furnace. *Metalurgija*. 2021;60:309-312.
- [8] Tarasov AV, Zajcev VI. Izvlechenie cennyh sostavlyayushchih iz shlakov mednogo proizvodstva [Extraction of valuable components from copper production slag]. *Cvetnaya metallurgiya = Non-ferrous metallurgy* 2011;7-8:60-67. (in Russ.).
- [9] Nus GS. Obednite'l'naya shlakovaya elektropech' – tekhnologicheskoe dolgoletie [Electric Furnace for Slag Depletion - Technological Longevity]. *Elektrometallurgiya = Electrometallurgy* 2009;7:33-36. (in Russ.).
- [10] Bellemans I, De Wilde E, Moelans N, Verbeken K. Metal losses in pyrometallurgical operations – A review. *Advances in Colloid and Interface Science*. 2018;255:47-63. <http://doi.org/10.1016/j.cis.2017.08.001>
- [11] Li Y, Chen Y, Tang C, Yang S, He J, Tang M. Co-treatment of waste smelting slags and gypsum wastes via reductive-sulfurizing smelting for valuable metals recovery. *Journal of Hazardous Materials*. 2017;322:402-412. <http://doi.org/10.1016/j.jhazmat.2016.10.028>.
- [12] Konig R, Degel R, Oterdoom H. Highly efficient slag cleaning – latest results from pilot-scale operation. *Proceedings of Copper 2013*. 2013;III:185-198.
- [13] Pat. 2441081 RF. Sposob pirometallurgicheskoy pererabotki med'soderzhashchih materialov [Method for pyrometallurgical processing of copper-containing materials]. SHashmurin NI, Posohov YUM, Zagajnov VS, Stukov MI, Kosogorov SA, Mamaev MV. *Publ. 27.01.2012, bull.1*. (in Russ.).
- [14] Kadyrov ED. Kompleksnaya avtomatizirovannaya sistema upravleniya pirometallurgicheskim proizvodstvom medi [Integrated automated control system for copper pyrometallurgical production]. *Zapiski Gornogo instituta = Notes of the Mining Institute* 2011;192:120-124. (in Russ.).
- [15] Danilova NV, Kadyrov ED. Primenenie nechetkoj logiki dlya modelirovaniya processa plavki medno-nikelevogo koncentrata v pechi Vanyukova [Application of Fuzzy Logic for Modeling the Process of Smelting Copper-Nickel Concentrate in the Vanyukov Furnace]. *Zapiski Gornogo instituta = Notes of the Mining Institute* 2011;192:107-110. (in Russ.).
- [16] Gorai B, Jana RK, Premchand. Characteristics and utilisation of copper slag - a review. *Resources conservation and recycling*. 2003;39(4):299-313. DOI 10.1016/S0921-3449(02)00171-4
- [17] Komkov AA, Ladygo EA, Byistrov SV. Issledovaniya povedeniya cvetnyh metallov v vosstanovitel'nyh usloviyah [Studies of the behavior of non-ferrous metals under reducing conditions]. *Cvetnye metally= Non-ferrous metals* 2003;6:32-37. (in Russ.).
- [18] Jalkanen H, Vehvilainen J, Poijarvi J. Copper in solidified copper smelter slags. *Scandinavian Journal of Metallurgy*. 2003;32:65-70. <http://doi.org/10.1034/j.1600-0692.2003.00536x>
- [19] Zander M, Friedrich B, Degel R, Kleinschmidt G, Hoppe M, Schmedl J. Improving copper recovery from production slags by advances stirring methods. *Proceeding of EMC 2011*. 2011;181-195.
- [20] Warczok A, Riveros G. Slag cleaning in crossed electric and magnetic fields. *Minerals Engineering*. 2007;20:34-43. <http://doi.org/10.1016/j.mineng.2006.04.07>
- [21] Fuerstenau MC, Jameson GJ, Yoon R-H. Froth flotation: a century of innovation. Littleton: SME, 2007;897.
- [22] Alp I, Deveci H, Sungun H. Utilization of flotation wastes of copper slag as raw material in cement production. *Journal of hazardous materials*. 2008;159(2-3):390-395. DOI 10.1016/j.jhazmat.2008.02.056

- [23] Shen H, Forssberg E. An overview of recovery of metals from slag. *Waste Management*. 2003;23:933-949. [http://doi.org/10.1016/S0956-053X\(02\)00164-2](http://doi.org/10.1016/S0956-053X(02)00164-2)
- [24] Muravyov MI, Fomchenko NV, Usoltsev AV, Vasilyev EA, Kondrat'eva TF. Leaching of copper and zinc from copper converter slag flotation tailings using H<sub>2</sub>SO<sub>4</sub> and biologically generated Fe-2(SO<sub>4</sub>). *Hydrometallurgy*. 2012;119:40-46. DOI 10.1016/j.hydromet.2012.03.001
- [25] Koizhanova AK, Kenzhaliyev BK, Kamalov EM, Erdenova MB, Magomedov DR, Abdylbaev NN. Research of gold extraction technology from technogenic raw material. *News of the National Academy of Sciences of the Republic of Kazakhstan. Series Chemistry and Technology*. 2020;1(439):95-101. <https://doi.org/10.32014/2020.2518-1491.12>
- [26] Kenzhaliyev BK, Surkova T Yu, Berkinbayeva AN. To the question of the intensification of the processes of uranium extraction from refractory raw materials. *Metalurgija*. 2018;58(1-2):75-78
- [27] Kuo CY, Wu CH, Lo SL. Removal of copper from industrial sludge by traditional and microwave acid extraction. *Journal of Hazardous Materials*. 2005;120:249-256. <http://doi.org/10.1016/j.jhazmat.2005.01.013>
- [28] Banza AN, Gock E, Kongolo K. Base metals recovery from copper smelter slag by oxidizing leaching and solvent extraction. *Hydrometallurgy*. 2002;67(1-3):63-69. DOI: 10.1016/S0304-386X(02)00138-X