



DOI: 10.31643/2019/6445.30
UDC 669.85/.86: 553.3/.4(574)
IRSTI 53.37.35



<https://creativecommons.org/licenses/by-nc-nd/3.0/>

Innovative technologies providing enhancement of non-ferrous, precious, rare and rare earth metals extraction

Kenzhaliyev B. K

Satbayev University, Institute of Metallurgy and Ore Beneficiation, Almaty, Kazakhstan

Received: 13 August 2019 / Peer reviewed: 27 August 2019 / Accepted: 10 September 2019

Abstract. The article provides the technologies of enrichment and metallurgy processing of mineral and man-made raw materials. New technical solutions are proposed to increase the end-to-end copper extraction, industrial products processing of copper production to obtain high purity selenium; extraction of gold from resistant mineral raw materials with the use of new reagents and equipment, processing of ferrous bauxite and alumina production waste, extraction of rare and rare earth metals from industrial products and wastes of chrome, phosphorus and uranium production, obtaining rhenium and Nickel-cobalt concentrate from the wastes of heat-resistant Nickel alloys. Innovative Bayer-hydrogenate technology of ferruginous bauxite processing was developed and tested using pilot facility. The technologies and equipment to produce a composite hydrogen permeable membrane based on niobium and obtaining castings of implants by casting method of titanium alloys with application of additive technologies were developed.

Keywords: mineral raw materials, processing, technologies, copper, selenium, gold, rare metals, rare earth metals, new materials.

Kenzhaliyev Bagdaulet Kenzhaliyevich – Candidate of technical sciences, Professor, General Director - Chairman of the Board of the Institute of Metallurgy and Ore Beneficiation, Vice-Rector for Scientific Research at Satbayev University, Almaty, Kazakhstan. E-mail: bagdaulet_k@satbayev.university, ORCID ID: 0000-0003-1474-8354

Introduction

Involvement of resistant, complex mineral and man-made raw materials into processing is challenging issue for the metallurgy industry over the world. Commercial exploitation of these raw materials is confined owing to lack of effective and profitable technologies.

The aim of enhancing end-to-end extraction of metals from ores, man-made wastes and secondary raw materials is crucial for the leading industry – non-ferrous metallurgy.

Thus, the processing of converter slag is one of the major production problems in the technology of copper sulfide concentrates processing. There are various methods of processing converter slag, both in liquid and solid form [1]. However, the available technologies do not allow for high recovery of precious metals [2]. The proposed technical solution is characterized by the fact that due to the use of a

complex reducing agent, the copper content in the slag is reduced to 0.7% compared to the existing indicator of 1.0% [3].

The technologies used of the selenium extraction from middlings of copper production provide roasting of selenium-containing materials and producing crude selenium (90% of the main component). The defective moment of the process is the formation of process gases that complicate the selenium purification [4, 5]. We have developed a reagent-free vacuum distillation technology for producing branded selenium (99.5% of the main component) [6].

90 % of selenium is obtained from copper-electrolyte slag, 10 % - from man-made products of the chemical and pulp and paper industry in the world [7]. There is no a technology for selenium production from the slags of sulfuric acid of copper plants, so they are sent to lead factories, or in the dumps. We

have developed a technology for processing slag from washing solutions to obtain ammonium perrenate and release selenium-containing slag into an independent man-made product [8].

When flotation of mineral raw materials compositions of collectors (flotation reagents), the mechanism of their interaction with the surface of minerals is determined by the activity of each component of the collector and the peculiar features of the surface of minerals [9]. The paper [10] shows the technological and economic efficiency of using a mixture of hexyl and butyl xanthogenates.

Performed flotation of gold-containing raw materials using a composite reagent allowed us to significantly reduce the consumption of reagents (an average of 20 %) to increase gold recovery by 2.0-2.2 %.

Pre-oxidation (roasting, autoclave process, bioleaching) are used for processing of resistant, mineral-complex ores, which is associated with additional operating costs, which can be compensated by higher extraction of gold from ores [11, 12].

We offer ore beneficiation technologies with the use of new modern technological devices and the use of pre-oxidation of the raw materials before cyanidation.

A waste disposal to obtain commercial products is required in order to ensure the profitability of alumina production in the processing of low-quality bauxite [13].

The studies provided has shown the principal possibility of creating an effective technology for processing waste products of alumina production to obtain iron oxide pigments, cast iron, titanium concentrate and construction materials [14]. The problem of efficient chromium-containing wastes disposal in the world has not been solved so far. In this regard, the studies of the complex processing of stale slags of ferrochrome production with the extraction of rare and rare earth metals are of great practical importance.

The technologies of rare earths elements extraction from the wet-process phosphoric acid by sorption are well-known [15, 16]. The weakness is the low degree of REM sorption (at least 25 %) due to the presence of iron, aluminum and thorium impurities. The technology developed by us for obtaining REM concentrate with the use of new sorbents will provide an increase in REM extraction, while reducing the negative impact of impurities.

Currently, the man-made raw materials are involved increasingly as a raw material source of the rare earth elements into industrial processing. Basically, it is red slime alumina production, ash and slag wastes from coal combustion, waste processing of phosphate ores [13, 17].

SARECO LLP produces a REE concentrate from the man-made mineral formations after the processing of phosphate uranium ores. The applied technology has a number of lacks: losses of rare earth elements with cake when refining productive solutions from impurities, a large consumption of reagents when a concentrate depositing. We propose an improved technology for the extraction of REE in the form of a concentrate from this type of raw material [18].

The wastes of heat-resistant nickel superalloys (HRNS) contain up to 9% of rhenium, 60% of nickel and 10% of cobalt and that is why their complex processing is required. There are known methods of processing wastes by electrolysis methods. In the patent [19], the electrochemical processing of HRNS wastes is carried out in a solution of hydrochloric acid, out of which nickel and cobalt are extracted as a concentrate. During the processing of HRNS wastes by the method of anodic dissolution in a nitric acid solution the nickel transferred to the solution is released at the cathode in the form of Ni-concentrate [20]. The lacks of the methods are the use of solutions of hydrochloric and nitric acids for opening wastes. In the process of electrolysis in the hydrochloric acid at high current densities, chlorine gas can be released, and special corrosion-resistant equipment is required for nitric acid solutions.

We have developed an electrochemical technology for processing HRNS wastes. Ni and Co can be extracted from the obtained solutions after rhenium extraction as a concentrate [21].

Thus, currently, the most important problem of the metallurgy industry is the development and implementation of innovative technologies that allow with the maximum completeness to extract non-ferrous, rare and rare earth metals contained in ores, industrial wastes and secondary raw materials.

In this paper, the issues of increasing the extraction of non-ferrous, noble, rare and rare earth metals in the complex processing of mineral, man-made and secondary raw materials are considered and new technical solutions are proposed.

Experiment and result discussion

The technology of depletion of copper slag dump of the Vanyukov furnace (VF) of the Balkhash copper-smelting plant of "Kazakhmys Smelting" was developed.

An appropriate composition of waste slags as to the main components (30-31% of silicon dioxide, no more than 5% of magnetite and no more than 5% of zinc in the slag, the moisture content in the feed stock – no more than 6.5%) has been developed. Dependences of copper content in a slag on magnetite content in it are obtained, which indicate negative

influence of magnetite (more than 8 %) on copper content in a slag (Figure 1).

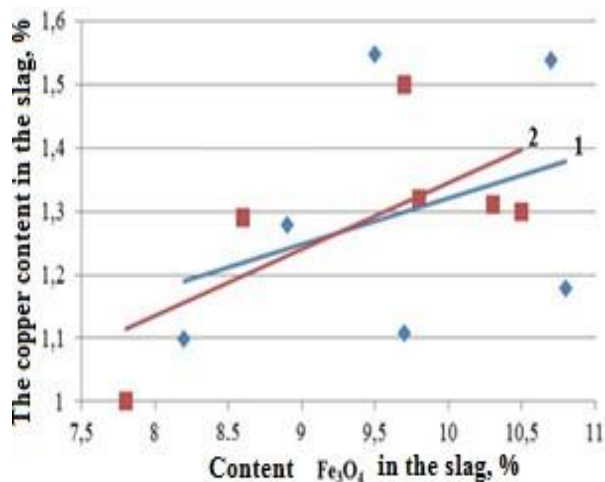
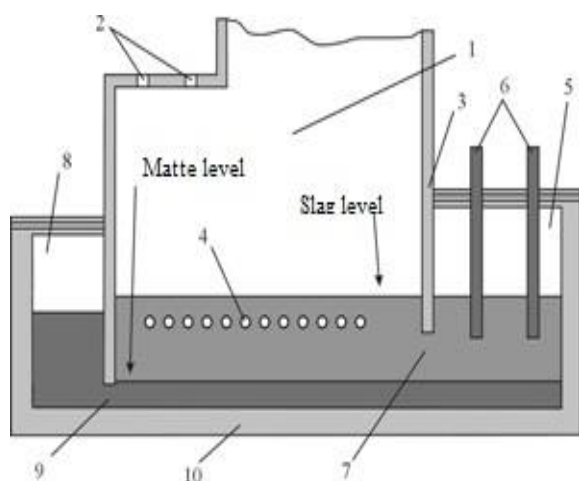

Figure 1 Dependence of copper content in the VF-1 slags (1) and VF-2 (2) on magnetite content

The use of additional electric heating is proposed to enhance the process of slag separation and matte in the slag siphon; the effective mode of the electric mixer of the Vanyukov furnace operation is developed (Figure 2). The introduction of technological and structural changes in the work of the VF complex allowed to increase the extraction of copper into the matte and to obtain a slag with a copper content of 0.5-0.7 %. In comparison with the existing analogues, the developed technology provides copper reduction in the waste slags from 1.0 to 0.7 % [22].



1 - uptake; 2 – for the feed stock; 3 - slag baffle; 4 - tuyere; 5 - slag siphon; 6 - electrodes; 7 - slag; 8 - matte siphon; 9 - matte; 10 –furnace bottom

Figure 2 Vanyukov Furnace

In the process of producing copper, the slurries of copper electrolyte and sulfuric acid production containing selenium are made. We have developed technology to extract elementary selenium from these middlings with further refining it into a vacuum distillation.

A method of separating selenium from a solution slurry after washing metallurgical gases of copper production is developed, installed material composition of selenium contained in the sludge. Appropriate conditions of sludge separation from the washing solution by centrifugation were determined [23].

As a result of vacuum distillation of rough selenium in the conditions of separation of the condensation surface by temperature zones in the middle zone, selenium containing 99.928% of the main component was obtained (Table 3). The proposed method allows to obtain refined selenium (up to 90% corresponding technical selenium 1 model and to 10% corresponding technical selenium 0 model) [24] in one stage [25].

Now, a production site for the processing of rough selenium according to the technology developed by us is arranged at the Kazakhmys Smelting LLP.

The technology of flotation enrichment of resistant, complex by mineral composition of gold-containing ores with the use of water-air microemulsion generator, improving the floatability of sludge particles, and composite flotation reagents is proposed (Table 1).

During flotation enrichment of Bestobe ores using microflotation and composite aerofloat, gold recovery increased by 4-5 %, while the reagent consumption decreased by 20% compared to the baseline [26].

When the gravitational enrichment of disseminated gold-bearing mineral raw materials a centrifugal separator was used to capture the free fine gold, which increased its recovery by 3-4 %. Enrichment of the gold-containing ore of the Sekisovsky Deposit on the centrifugal apparatus in the appropriate mode showed the possibility of obtaining a heavy fraction with a mass fraction of 58.9 g/t at the extraction of 21.57 % (Table 2) [27].

Table 1 Flotation parameters comparing by using the developed air-water microemulsion generator

Parameters	General mode	With generator
Bubble size	300 - 550 μm	20 - 50 μm
Time of flotation	15 - 24 min	11 - 17 min
Valuable components loss	20 – 25 %	15-20 %

Table 2 The results of gold ore enrichment using centrifugal separator

Products	Output, %	Gold content, g/t	Gold extraction, %
Concentrate 1 of Knelson recleaning	2.03	58.9	21.57
Middling 1 of recleaning	13.0	8.68	20.23
Knelson tails	84.97	3.8	58.2
Base ore	100.0	5.55	100.0

The technology of gold extraction from refractory gold-containing ores with the use of pre-oxidation has been developed. The appropriate parameters of leaching refractory ores of JSC "Altyntau-Kokshetau" with the use of the reagents- activators of Na_2O_2 oxidation and $\text{Ca}(\text{ClO})_2$ (1 g/t), at this the degree of gold extraction at S:L = 1 : 3 for 24 h amounted to 73.1 %, which is higher than production performances (60-65 %) Table 4) [28].

A waste-free resource and energy-saving Bayer-hydrogarnet technology for processing ferruginous bauxite has been developed. A pilot

Table 3 The results of x-ray fluorescence analysis of powdered selenium

Element	Se*	Te	Sb	Ca	Mg	Si	Al	Fe	Ni	Pb	Cu	As	S
mass %	99.928	0.054	0.01	0.001	0.01	0.01	0.001	0.001	0.001	0.001	0.001	0.001	0.001

*N/D: Hg, Ag, Cd, Na, K, Bi, Ti, Cl⁻

Table 4 The results of the gold extraction out of ore using oxidizing reagents

No. of sample	1	2	3	4
Sample weight, g	100.0	100.0	100.0	100.0
pH	11.6	11.3	12.0	11.6
Liquid phase, l	0.3	0.3	0.3	0.3
The concentration of cyanide, %	0.1	0.1	0.1	0.1
The gold content in a cake, g	0.45	0.43	0.63	0.65
The gold content in the base ore, g	1.6	1.6	1.6	1.6
Gold extraction, %	71.9	73.1	60.6	59.4

plant has been created and Bayer-hydrogarnet technology has been tested with the production of pilot batches of products: production alumina, micronized aluminum hydroxide, hydrogarnet sludge, samples of building bricks made of slag and hydrogarnet sludge.

A technological regulation have been prepared and a feasibility study has been carried out for the construction of an alumina refinery with a capacity of 1 million tons per year in the Kostanay Region of the Republic of Kazakhstan. The industrial implementation of the new technology will provide higher performance compared to the Bayer sintering process: it will provide a 35% reduction in energy costs; saving soda ash by 90%, reducing environmentally harmful emissions by 2–3 times and reducing capital costs for the construction of an

alumina plant with a capacity of 1.0 million tons by 25% [29, 30].

A technological scheme has been developed for the non-waste processing of red slurry (waste after alumina production) to produce iron oxide pigments, cast iron, titanium dioxide concentrate and construction materials [31].

The parameters of the hydrochemical processing of ferruginous sand with the release of iron-containing cake to obtain iron oxide pigments and cast iron are determined. In a high-modulus alkaline solution with the addition of CaO , the maximum extraction of Al_2O_3 (58.2%) in the solution was achieved by leaching of ferrous sands after firing at a temperature of 600 °C at a molar ratio in the CaO pulp: $\text{SiO}_2 = 2$ (Figure 3).

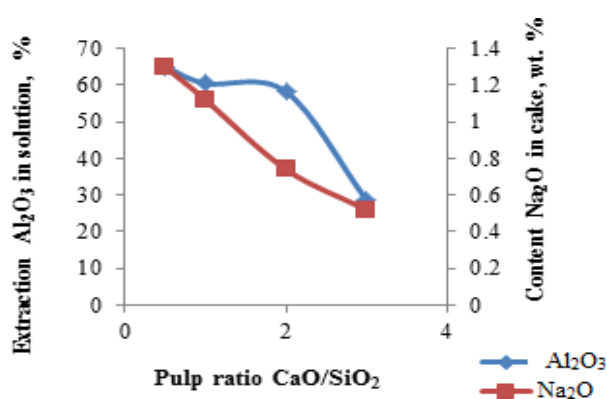
**Figure 3** Impact of the $\text{CaO} / \text{SiO}_2$ ratio on the extraction of Al_2O_3

Sodium-ferrite clinker with a sodium ferrite content of 62.4% was synthesized from the man-made raw materials - red slurry, iron oxide, soda ash sodium ferrite clinker and lime. The color of the pigment is determined by the iron compounds contained in it: α -Fe₂O₃ oxide, iron oxide — substituted by Fe_{2-x}M_xO₃. [32].

A technology has been developed for the processing of ferruginous sand of alumina production, including the operation of calcining ferruginous sand at 600 °C, hydrochemical hydrogarnet processing in a high-modulus alkaline solution at a temperature of 240-260 °C with the addition of CaO to produce an aluminate solution and a hydrogarnet cake leaching, magnetic separation of the cake with fine separation fractions to obtain pigments, reductive melting of the magnetic fraction to produce cast iron and slag. The obtained fine fraction was analyzed by Mossbauer spectroscopy. It was found that the red-brown color of the fraction is determined by α -Fe₂O₃ oxide and substituted iron oxide Fe_{2-x}M_xO₃. Paramagnetic Fe³⁺ phases are a mixture of hydroxides β -FeOOH - acaganeite and γ -FeOOH - lepidocrocite (Figure 4) [33].

The studies for the deep processing of chromite-containing dusts from ferrochrome production to obtain chromite concentrate, gallium, vanadium pentoxide and rare-earth metal concentrate were carried out (Table 5).

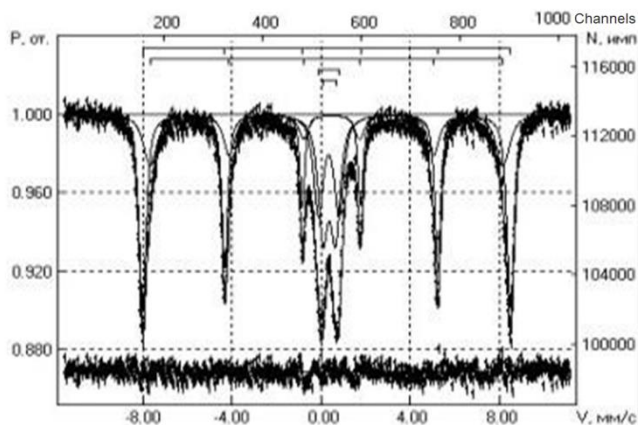

Figure 4 Mossbauer spectrum of a finely divided fraction of iron-containing leach cake of calcined ferrous sands

Table 5 Rare metals concentration in the base products

Chemical compound	Cyclone filter dust	Bag filter dust	Enrichment sludge	Wet scrubbing slurry
	Content, %			
TiO ₂	0,153	0,122	0,0136	0,15
V ₂ O ₅	0,062	0,033	0,0053	0,045
Ga ₂ O ₃	0,008	0,027	0,005	0,033
Rb ₂ O	0,00104	0,012	0,003	0,001
ΣPЗЭ	0,01624	0,04581	0,04711	0,06467

and limestone. Red-brown iron oxide pigment with a particle size of 0.17 microns was obtained by the autoclave leaching of a mixture of red slurry,

The conditions for the extraction of REE out of the dust of cyclone and bag filters of JSC TNC Kazchrome are determined. The recovery of REE during leaching in NH₄HSO₄ solutions with a concentration of 3-30% ranged from 69.42 to 96.1%. A solution containing 10% of NH₄HSO₄ is considered appropriate for the REE isolation, while Cr₂O₃, SiO₂ and Fe₂O₃ extraction does not occur in the solution, and the REE extraction is 73.83% (Figure 5)

The methods of preliminary chemical activation and sulfuric acid leaching of chromite-containing raw materials, as well as of regeneration of ammonium hydrosulfate have been developed [34].

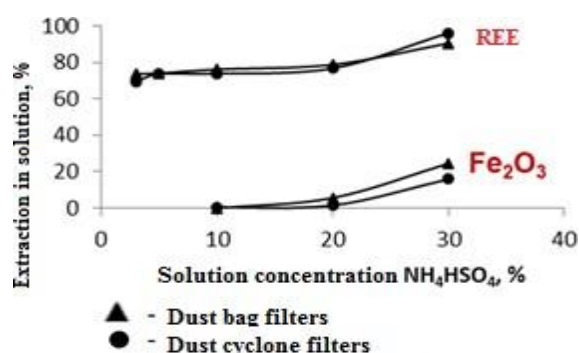

Figure 5 Dependence of the REE extraction and Fe₂O₃ into solution after NH₄HSO₄ concentration

A method has been developed to obtain REM concentrate from the extraction phosphoric acid of Mineral Fertilizers Plant LLP of Kazphosphate LLP using new sorbents. The sorption of rare-earth metals from solutions of extraction phosphoric acid by various ion exchangers was studied. It was found that sorption of rare-earth metals from extraction phosphoric acid most efficiently takes place on Purosorb 140 cation exchange resin (Figure 6). The equilibrium parameters of sorption of rare-earth metals from EPA were determined: 100 min. duration, 25-30 °C, ratio L:S = 50:1. Purosorb 140 ionite is recommended for the extraction of rare-earth metals out of extraction phosphoric acid [35].

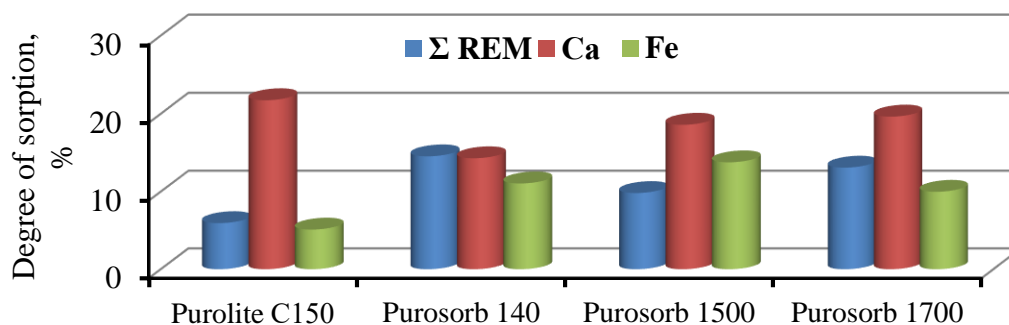

Figure 6 The degree of sorption of the rare-earth metals sum, calcium and iron from EPA on various cation exchangers

In order to improve the existing technology for processing man-made wastes from the processing of phosphate uranium ores, in particular, to reduce the consumption of sulfuric acid during their leaching, we have proposed a method involving preliminary calcination of the feedstock at a temperature of 400-500 °C in the presence of ammonium sulfate. It has been established that at this temperature sulfate ammonium is transformed into bisulfate and in the process of leaching of raw materials, forming an acid-salt mixture with sulfuric acid, helps to reduce the consumption of sulfur acid 4–5 times (Figure 7) [36, 37].

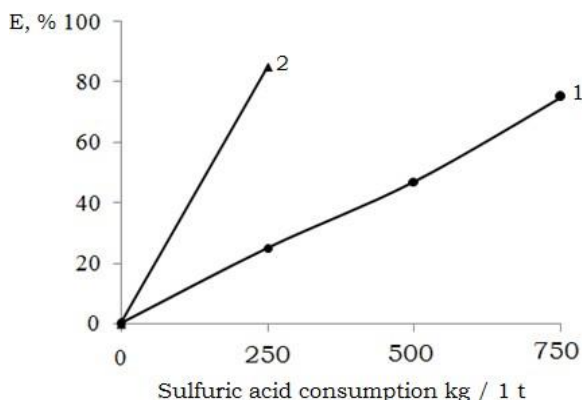

Figure 7 Dependence of sulfuric acid consumption on the degree of REE extraction

1 - existing technology, 2 - proposed technology

We have developed an electrochemical technology for processing secondary raw materials – wastes of heat-resistant nickel superalloys, which is currently being introduced at the REM Zhezkazganredmet. The technology consists in combining anodic dissolution of waste in a sulfuric acid solution with the transfer of rhenium, nickel and cobalt into the solution and the precipitation of nickel-cobalt concentrate after extraction of rhenium from it.

When leaching in a sulfuric acid solution with nitric acid additives, Ni and Co almost completely go into solution, Re - by 75% (Figure 7). With a ratio of

S:L = 1:20; at a temperature of 50 °C, the degree of transition to a solution of nickel and cobalt reaches 80-95%, rhenium - 75-85%. Received Nickel-cobalt concentrate with a content, wt. %: 13.24-14.98 Ni and 0.96-1.08 Co [38].

Composite hydrogen-permeable membranes based on niobium and tantalum were obtained by developing separation layers that ensure the stability of the properties of catalytic protective coatings based on palladium and a scheme for attaching the membrane to a flat substrate, which promotes uniform distribution of stresses in the membrane (Figure 8) [39]. The research results are recommended

to be used to arrange innovative production of modules for producing ultra-pure hydrogen from hydrogen-containing gas mixtures.

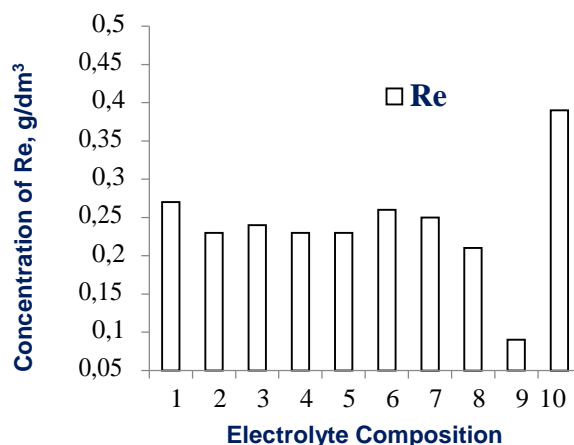

Electrolyte composition, g/dm³: 1 - 100 H₂SO₄; 2 – 10

H₂SO₄; 70 (NH₄)₂SO₄; 125,2 Na₂SO₄·10H₂O; 3 - 20 H₂SO₄; 40 (NH₄)₂SO₄; 90,7 Na₂SO₄·10H₂O; 4 – 20 H₂SO₄; 40 (NH₄)₂SO₄; 90,7 Na₂SO₄·10H₂O; 20 NaCl; 5 – 20 H₂SO₄; 40 (NH₄)₂SO₄; 90,7 Na₂SO₄·10H₂O; 20 HCl; 6 - 150 H₂SO₄; 7 - 200 H₂SO₄; 8 - 150 H₂SO₄; 20 NaCl; 9 - 200 H₂SO₄; 30 NaCl; 10 - 100 H₂SO₄; 20 HNO₃

Figure 7 Impact of the initial electrolyte composition on the concentration of rhenium in the solution after anodic dissolution of alloy wastes



Figure 8 Upgraded chamber of the magnetron sputtering installation and the surface of the membrane of tantalum and niobium foil

A technology has been developed for the production of implants with improved osseointegration by casting of titanium alloys using a lost-wax 3D model and subsequent processing with application of biocompatible coatings (Figure 9).

Molding materials based on yttrium oxide and a method for their molding on the surface of investment models are proposed, which provides titanium castings with a developed surface using additive technology [40].

The analysis of the feedstock and the obtained products was performed using the following methods: mineralogical, X-ray phase, X-ray fluorescence, thermal analysis methods, electron scanning microscopy, IR spectroscopy, Mossbauer spectroscopy.

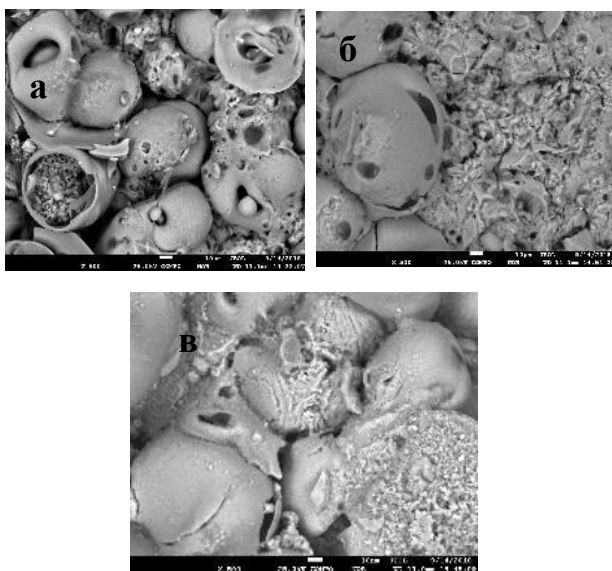

Figure 9 SEM image of a calcium phosphate coating obtained at different pH of electrolytes: a - pH 1; pH 2; pH 3

Elemental analysis was carried out using X-ray fluorescence spectroscopy on an energy dispersive microanalysis system INCA Energy 450 mounted on a scanning electron microscope JSM 6610 LV, JEOL.

X-ray phase analysis. The shooting was carried out on a D8Advance (Bruker) apparatus, α -Cu. Processing of the obtained results and calculation of interplanar distances was carried out using the EVA software. The phase decoding was performed using the PDF-2 diffractometric database.

Mossbauer spectroscopy was used to determine the forms of iron in the feedstock and processing products. The source was Co-57 in a chromium matrix with an activity of 100 mCi. The spectra were processed on a PC using the "least squares" method. The values of isomeric shifts (IS) are given relative to α -Fe. The temperature of the spectra was 293 K. The MS 1104Em spectrometer.

Images of objects using scanning electron microscopy were performed at zooming from 40 to 4000 times.

Conclusion

To sum up, the technologies have been created that are focused on the needs of industrial enterprises: processing dump and converter slags with additional copper recovery, separating selenium from washing solutions of copper production and obtaining refined selenium (Kazakhmys Smelting LLP); processing of ferruginous bauxite and industrial products and waste from alumina production (JSC Aluminum of Kazakhstan); processing of refractory gold-containing ores (MSC Altyn MM LLP, Altyntau-Kokshetau JSC); extraction of rare and rare-earth metals from wastes and middlings of chromium, phosphorus and uranium production (JSC TNK Kazkhrom, LLP Kazphosphate, JSC NAC Kazatomprom); for producing nickel-cobalt concentrate from heat-resistant nickel superalloys wastes (RGP Zhezkazganredmet), synthesis of composite hydrogen-permeable membranes based on niobium and tantalum and implants with improved osseointegration.

The technologies for the processing of low-quality mineral and industrial raw materials may be of interest to countries with similar raw materials.

Acknowledgement. The studies were carried out with the financial support of the Science Committee of the Ministry of Education and Science of the Republic of Kazakhstan within the framework of Program No. BR05236406 "Development and implementation of innovative technologies that enhance the extraction of non-ferrous, noble, rare, rare-earth metals and solve production problems of industrial enterprises of the State".

Cite this article as: Kenzhaliyev B. K. Innovative technologies providing enhancement of non-ferrous, precious, rare and rare earth metals extraction // Kompleksnoe Ispol'zovanie Mineral'nogo Syr'a (Complex Use of Mineral Resources). – 2019. – №3 (310). -Page: 64-75 <https://doi.org/10.31643/2019/6445.30>

Түсті, асыл, сирек және сирек жер металдардың бөлінуін арттыруды қамтамасыз ететін инновациялық технологиялар

Кенжалиев Б. К.

Түйіндеме. Мақалада байыту және минералдық, техногендік шикізатты металлургиялық қайта өңдеу, функционалдық материалдар алу технологиялары келтірілген. Мысты тікелей бөліп алуды арттыру, таза селен алынатын мыс өндірісінің өнеркәсіптік өнімдерін қайта өңдеу, жаңа реагенттер мен жабдықтарды пайдаланып қиын өңделетін минералдық шикізаттан алтынды бөліп алу, темірлі бокситтерді және сазтопырақ өндірісінің қалдықтарын қайта өңдеу, хром, фосфор және уран өндірісінің өнеркәсіптік өнімдері мен қалдықтарынан сирек және сирек жер металдарын бөліп алу, отқа төзімді никель қорытпаларының қалдықтарынан рений және никель-кобальтты концентраттарды алу бойынша жаңа технологиялық шешімдер ұсынылды. Темірлі бокситтерді өңдеудің инновациялық Байер-гидрогранаттық технологиясы жасалды және құрылған пилоттық қондырғыда оның сынағы өткізілді. Ниобий негізінде сутегі өткізетін композициялық мембраналарды және аддитивті технологияларды пайдаланып титан қорытпаларын құю әдісімен эндопротездердің құймаларын алу үшін технологиялар және қондырғылар әзірленді.

Түйін сөздер: минералдық шикізат, өңдеу, технология, мыс, селен, алтын, сирек металдар, сирек жер металдары, жаңа материалдар.

Инновационные технологии, обеспечивающие повышение извлечения цветных, благородных, редких и редкоземельных металлов

Кенжалиев Б.К.

Реферат. В статье представлены разработанные в АО «Институт металлургии и обогащения» (г. Алматы, Казахстан) технологии обогащения и металлургической переработки минерального и техногенного сырья, получения функциональных материалов. Предложены новые технические решения по увеличению сквозного извлечения меди, переработке промпродуктов медного производства с получением селена высокой чистоты; извлечению золота из упорного минерального сырья с применением новых реагентов и оборудования, переработке железистых бокситов и отходов глиноземного производства, извлечению редких и редкоземельных металлов из промпродуктов и отходов хромового, фосфорного и уранового производств, получению рения и никель-кобальтового концентрата из отходов жаропрочных никелевых сплавов. Разработана инновационная Байер-гидрогранатовая технология переработки железистых бокситов и проведены ее испытания на созданной пилотной установке. Разработаны технологии и оборудование для получения композиционных водородопроницаемых мембран на основе ниобия и получения отливок эндопротезов методом литья титановых сплавов с применением аддитивных технологий.

Ключевые слова: минеральное сырье, переработка, технологии, медь, селен, золото, редкие металлы, редкоземельные металлы, новые материалы.

REFERENCES

- [1] Coursol P., Valencia N.C., Macrey P., Bell S., Davis B. Minimization of Copper losses in Copper Smelting Slag During Electric Furnace Treatment // JOM (The Journal of The Minerals, Metals & Materials Society (TMS). **2012**. Vol.64. №11. Pp.1305-1313 (In Eng.). <https://doi.org/10.1007/s11837-012-0454-6>
- [2] G.R.F. Alvear F., Hourn M. and J.C. Salas M. Xstrata Technology's Approach for the Processing of Copper Bearing Materials // Proceedings of Copper 2013. Santiago, Chile, **2013**. V.3. Pp.389-400 (In Eng.).
- [3] Kozhakhmetov S., Kvyatkovskiy S. The main results of research and industrial development of Vanyukov process in Kazakhstan // Vanyukov International Symposium on Sustainable Industrial Processing Summit & Exhibition. Turkey. **2016**. V.5. P.267-272 (In Eng.).

- [4] Azhazha V.M., Papirova I.I., Shkuropatenko V.A., Lavrenovich A.G., Virich V.D. Rafinirovaniye vtorichnogo selena distillyatsionnymi metodami // Voprosy atomnoy nauki i tekhniki. **2004.** №6. Seriya: Vakuum, chistyye materialy, sverkhprovodniki (14). S.21-23 (In Rus.).
- [5] Areshina N.S., Kasikov A.G., Mal'ts I.E., Zenkevich T.R. Izvlecheniye selena iz produktov gazoochistki OAO «Kol'skaya GMK» //Tsvetnyye metally. **2011.** №11. S.62-65 (In Rus.).
- [6] Patent 32113 RK Apparat dlya rafinirovaniya selena /Volodin V.N., Trebukhov S.A., Abisheva Z.S., Marki I.A., Nitsenko A.V., Trebukhov A.A., Burabayeva N.M., Tuleutay F.KH. opubl. 30.05.**2017.** Byul. №10 (In Rus.).
- [7] Lebed' A. B., Naboychenko S. S., Shunin V. A. Proizvodstvo selena i tellura na OAO «Uralektromed». Yekaterinburg: Ural'skiy universitet, **2015.** 112 s. (In Rus.).
- [8] Zagorodnyaya A. N., Abisheva Z. S., Sharipova A. S., Zhumabekov ZH. ZH. Polupromyshlennyye ispytaniya sorbtsionnoy tekhnologii izvlecheniya reniya iz stochnykh vod ot promyvki metallurgicheskikh gazov Balkhashskogo medeplavil'nogo zavoda // Tsvetnyye metally. **2016.** №1. S. 49-55 (In Rus.). <https://doi.org/10.17580/tsm.2016.01.08>
- [9] Ignatkina V.A., Bocharov V.A., Tubdenova B.T. K poisku rezhimov selektivnoy flotatsii sul'fidnykh rud na osnove sochetaniya sobirateley razlichnykh klassov soyedineniy //Fiziko-tekhnicheskiye problemy razrabotki poleznykh iskopayemykh. **2010.** №1. S.97-104 (In Rus.).
- [10] Otrozhdenova L. A., Ryabov V. I., Kuchayev V. A., Malinovskaya N. D. Flotatsiya mednykh sul'fidnykh rud geksilovym ksantogenatom firmy «Khokhst» //Obogashcheniye rud. **2010.** №4. S.12-16 (In Rus.).
- [11] Advances in gold ore processing / M.D. Adams (Editor). Guilford: Mutis Liber PTY LTD, **2005.** Pp. 1076 (In Eng.).
- [12] Gold-Copper Ores // Innovations in Gold and Silver Recovery: Phase IV / Randol Int Ltd.- Colorado, USA. **1992.** V.8. Chapt 23. P.4175-4428 (In Eng.).
- [13] Borra C.R., Pontikes Y., Binnemans K., Gerven T.V. Leaching of rare earths from bauxite residue (red mud) // Minerals Engineering. **2015.** No76. Pp. 20-27 (In Eng.). <https://doi.org/10.1016/j.mineng.2015.01.005>
- [14] Patent №25938 RK Sposob pererabotki krasnogo shlama Byul.№7, opubl.15.07.**2015** g. /Abdulvaliyev R.A., Beysembekova K.O., Gladyshev S.V., Kovzalenko V.A., Ibragimov A.T., Sabitov A.R., Tastanov Ye.A. (In Rus.).
- [15] Lokshin E.P., Ivanenko V.I., Tareyeva O.A., Korneyko R.I. Izvlecheniye lantanoidov iz fosfornokislykh rastvorov s ispol'zovaniyem sorbtsionnykh metodov /Zhurnal prikladnoy khimii. **2009.** T.82. №4. S.544-551 (In Rus.).
- [16] Mikhaylichenko A.I., Papkova M.V., Kon'kova T.V., Tumanov V.V. Sorbtsionnoye izvlecheniye RZE iz rastvorov fosfornoj kisloty. M., **2014.** S.51-55 (In Rus.).
- [17] Kosynkin V.D., Selivanovskiy T.T., Smirnov K.M., Krylova O.K. Kompleksnaya pererabotka fosfogipsa s polucheniym khimicheskii osazhdennogo mela, gipsa i kontsentrata redkozemel'nykh elementov //Tsvetnyye metally. **2012.** №3. S.31-34 (In Rus.).
- [18] Patent 24889 RK. Sposob izvlecheniya redkozemel'nykh elementov iz matochnykh rastvorov uranovogo proizvodstva / Surkova T.YU., Mukusheva A.S., Yulusov S.B., Dulinin A.P., Gushchin A.P., Barmenshinova M.B. Opubl. 15.12.**2014.** Byul. №12 (In Rus.).
- [19] Patent 10155791 DE. Process for electrochemical decomposition of superalloys / Stoller Viktor et al. **2003** (In Eng.).
- [20] Chernysheva O.V., Drobot D.V. Varianty elektrokhimicheskoy pererabotki reniysoderzhashchego zharoprochnogo splava // Khimicheskaya tekhnologiya. **2017.** Tom 18. №1. S. 36-42 (In Rus.).
- [21] Agapova L.YA., Abisheva Z.S., Kilibayeva S.K., Yakhliyayeva ZH.Ye. Elektrokhimicheskaya pererabotka tekhnogennykh otkhodov reniysoderzhashchikh zharoprochnykh nikel'nykh splavov v sernokislykh rastvorakh //Tsvetnyye metally. **2017.** №10. S 56-61 (In Rus.).
- [22] Kenzhaliyev B.K., Kvyatkovskiy S. A., Kozhakhmetov S. M., Sokolovskaya L. V., Semenova A. S. (**2018**). Depletion of waste slag of balkhash copper smelter. Kompleksnoe Ispol'zovanie Mineral'nogo syr'â. 306 (3), 45–53 (In Rus.). <https://doi.org/10.31643/2018/6445.16>
- [23] Zagorodnyaya A.N. Shlam sernokislotochnogo tsekha balkhashskogo medeplavil'nogo zavoda - al'ternativnyy istochnik polucheniya selena na predpriyatii // Kompleksnoe Ispol'zovanie Mineral'nogo syr'â. - **2018.** - No. 4. - p. 46-55 (In Rus.). <https://doi.org/10.31643/2018/6445.29>
- [24] GOST 10298-79 (State standard). Selen tekhnicheskii. Tekhnicheskiye usloviya. IUS No.4. **2004.** <http://docs.cntd.ru/document/gost-10298-79> (In Russ.).
- [25] Kenzhaliyev B.K., Trebukhov S.A., Volodin V.N., Trebukhov A.A., Tuleutay F.KH. Izvlecheniye selena iz promproduktov metallurgicheskogo proizvodstva // Kompleksnoe Ispol'zovanie Mineral'nogo syr'â. - **2018.** - No. 4. - p. 11-16 (In Rus.). <https://doi.org/10.31643/2018/6445.30>
- [26] Rulyov N., Tussupbayev N., Turusbekov D., Semushkina L., Kaldybayeva Z. Effect of microbubbles as flotation carriers on finesulphide ore beneficiation // Mineral Processing and Extractive Metallurgy. - **2018.** - Vol.127. - N.3. - Pp.133–139 (In Eng.). <https://doi.org/10.1080/03719553.2017.1351067>
- [27] Abdylidayev N. N., Koizhanova A. K., Kamalov E. M., Zhanabay ZH. D., Akchulakova S. T. Doizvlecheniye zolota v kontsentrata iz lezhalykh khvostov metodom flotatsii // Kompleksnoe Ispol'zovanie Mineral'nogo syr'â. – **2018.** – №4. – p. 11-16 (In Rus.). <https://doi.org/10.31643/2018/6445.25>
- [28] Erdenova M., Kenzhaliyev B., Koizhanova A., Temirova S., Abdylidayev N. Extraction of gold from man-made mineral raw materials by Methods of flotation enrichment and cyaning // 18th International Multidisciplinary

Scientific GeoConference SGEM **2018**, Science and Technologies in Geology, Exploration and Mining (In Eng.). <https://doi.org/10.5593/sgem2018/1.4/s04.009>

[29] Kenzhaliev B.K., Kuldeev E.I., Abdulvaliev R.A., Pozmogov V.A., Beisembekova, K.O., Gladyshev S.V., Tastanov E.A. Perspektivy razvitiya alyuminiyevoy otrasli Kazakhstana //Izvestiya NAN RK Seriya geologii i tekhnicheskikh nauk. **2017**. No. 3. S.151-160 (In Rus.).

[30] Patent of the Republic of Kazakhstan No. 30113. Sposob pererabotki nizko-kachestvennykh zhelezistykh boksitov po Bayer-gidrogranatovoy tekhnologii / Abdulvaliyev R.A., Gladyshev S.V., Tastanov Ye.A. ; opubl. 08/15/2016 (In Rus.).

[31] Patent RK No. 33499. Sposob pererabotki krasnogo shlama / Kenzhaliyev B.K., Akhmadiyeva N.K., Abdulvaliyev R.A., Gladyshev S.V., Omarova S.A., Manapova A.I., Zinov'yeva L.V. ot March 7, **2019**. Byul No. 10 (In Rus.).

[32] Gladyshev S.V., Abdulvaliyev R.A., Kenzhaliyev B.K., Dyusenova S.B., Imangaliyeva L.M. Razrabotka tekhnologii polucheniya khromitovogo kontsentrata iz shlamovykh khvostov obogashcheniya // Kompleksnoe Ispol'zovanie Mineral'nogo syr'â (Complex Use of Mineral Resources). - **2018**. - No. 1. - S.12-17 (In Rus.). <https://doi.org/10.31643/2018/166445>

[33] Dyusenova S.B., Kenzhaliyev B.K., Abdulvaliyev R.A., Gladyshev S.V. Kompleksnaya gidrokhimicheskaya pererabotka shlamovykh khvostov obogashcheniya khromitsoderzhashchikh rud // Obogashcheniye rud. - № 6. - **2018**. - S. 27-32. (In Rus.).

[34] Pozmogov V.A., Kuldeev E.I., Dorofeev D.V., Imangaliyeva L.M., Kvyatkovskaya M.L. Determination of physicochemical properties and phase composition of ferrous sands of alumina production to find ways for their further processing // Kompleksnoe Ispol'zovanie Mineral'nogo syr'â (Complex Use of Mineral Resources). - **2018**. - No. 3. - S. 69-77 (In Rus.). <https://doi.org/10.31643/2018/6445.19>

[35] Lokhova N.G., Naimanbaev M.A., Baltabekova Zh. A., Kasymzhanov K. K. (**2018**). Sorption rerecovery and concentration of rare-earth metals from extraction phosphoric acid. Review Kompleksnoe Ispol'zovanie Mineral'nogo syr'â. 306 (3), 62–68 (In Rus.). <https://doi.org/10.31643/2018/6445.18>

[36] Kenzhaliyev B.K., Yesimova D.M., Surkova T.YU., Amanzholova L.U., Akchulakova S.T. Podgotovka produktivnykh rastvorov dlya izvlecheniya redkozemel'nykh elementov // Vestnik KazNITU. - **2018**. - No. 5. - S.367-373 (In Rus.).

[37] Patent RK No. 33153 Sposob izvlecheniya redkozemel'nykh elementov iz kremnistogo syr'ya / Kenzhaliyev B.K., Surkova T.YU., Yulusov S.B., Pirmatov E.A., Dulinin A.P. ot 10/01/2018 (In Rus.).

[38] Agapova L.YA., Kenzhaliyev B.K., Abisheva Z.S., Kilibayeva S.K., Yakhliyayeva ZH.Ye., Altenova A.N., Ruzakhunova G.S. Polucheniye nikel'-kobal'tovogo kontsentrata iz otkhodov zharoprochnykh nikel'evykh splavov // Trudy Kol'skogo nauchnogo tsentra RAN. Khimiya i materialovedeniye. - **2018**.- No. 2 1/2018 (9), CH.2. - S. 798 – 803 (In Rus.).

[39] Panichkin A.V., Mamayeva A.A., Derbisalin A.M., Kenzhegulov A.K., Imbarova A.T. Vliyaniye sostava nanosimyykh na forekhnost' plenok tverdykh rastvorov na kharakteristiki vodorodopronitsayemykh membran iz niobiya i tantala // Kompleksnoe Ispol'zovanie Mineral'nogo syr'â. - **2018**. - No. 4. - p. 130-139 (In Rus.). <https://doi.org/10.31643/2018/6445.39>

[40] Mamaeva, A. A., Kenzhegulov, A. K., & Panichkin, A. V. (**2018**). A Study of the Influence of Thermal Treatment on Hydroxyapatite Coating. Protection of Metals and Physical Chemistry of Surfaces, 54 (3), 448–452 (In Eng.). <https://doi.org/10.1134/s2070205118030115>

ЛИТЕРАТУРА

[1] Coursol P., Valencia N.C., Macrey P., Bell S., Davis B. Minimization of Copper losses in Copper Smelting Slag During Electric Furnace Treatment // JOM (The Journal of The Minerals, Metals & Materials Society. 2012. Vol.64. №11. Pp.1305-1313. <https://doi.org/10.1007/s11837-012-0454-6>

[2] G.R.F. Alvear F., Hourn M. and J.C. Salas M. Xstrata Technology's Approach for the Processing of Copper Bearing Materials // Proceedings of Copper 2013. Santiago, Chile, 2013. V.3. Pp.389-400.

[3] Kozhakhmetov S., Kvyatkovskiy S. The main results of research and industrial development of Vanyukov process in Kazakhstan //Vanyukov International Symposium on Sustainable Industrial Processing Summit & Exhibition. Анталья, 2016. V.5. P.267-272.

[4] Ажажа В.М., Папиоров И.И., Шкуропатенко В.А., Лавренович А.Г., Вирич В.Д. Рафинирование вторичного селена дистилляционными методами // Вопросы атомной науки и техники. 2004. №6. Серия: Вакуум, чистые материалы, сверхпроводники (14). С.21-23.

[5] Арешина Н.С., Касиков А.Г., Мальц И.Э., Зенкевич Т.Р. Извлечение селена из продуктов газоочистки ОАО «Кольская ГМК» //Цветные металлы. 2011. №11. С.62-65.

[6] Патент 32113 РК Аппарат для рафинирования селена /Володин В.Н., Требухов С.А., Абишева З.С., Марки И.А., Нищенко А.В., Требухов А.А., Бурабаева Н.М., Тулеутай Ф.Х. опубл. 30.05.2017. Бюл.№10.

[7] Лебедь А. Б., Набойченко С. С., Шунин В. А. Производство селена и теллура на ОАО «Уралэлектромедь». Екатеринбург: Уральский университет, 2015. 112 с.

- [8] Загородняя А. Н., Абишева З. С., Шарипова А. С., Жумабеков Ж. Ж. Полупромышленные испытания сорбционной технологии извлечения рения из сточных вод от промывки металлургических газов Балхашского медеплавильного завода // Цветные металлы. 2016. №1. С. 49-55. <https://doi.org/10.17580/tsm.2016.01.08>
- [9] Игнаткина В.А., Бочаров В.А., Тубденова Б.Т. К поиску режимов селективной флотации сульфидных руд на основе сочетания собирателей различных классов соединений // Физико-технические проблемы разработки полезных ископаемых. 2010. №1. С.97-104
- [10] Отрожденова Л. А., Рябой В. И., Кучаев В. А., Малиновская Н. Д. Флотация медных сульфидных руд гексилловым ксантогенатом фирмы «Хёхст» // Обогащение руд. 2010. №4. С.12-16.
- [11] Advances in gold ore processing / M.D. Adams (Editor). Guilford: Mutis Liber PTY LTD, 2005. Pp. 1076.
- [12] Gold-Copper Ores // Innovations in Gold and Silver Recovery: Phase IV / Randol Int Ltd.- Colorado, USA. 1992. V.8. Chapt 23. P.4175-4428.
- [13] Borra C.R., Pontikes Y., Binnemans K., Gerven T.V. Leaching of rare earths from bauxite residue (red mud) // Minerals Engineering. 2015. №76. Pp. 20-27. <https://doi.org/10.1016/j.mineng.2015.01.005>
- [14] Патент №25938 РК Способ переработки красного шлама Бюл.№7, опубл.15.07.2015 г. /Абдулвалиев Р.А., Бейсембекова К.О., Гладышев С.В., Ковзаленко В.А., Ибрагимов А.Т., Сабитов А.Р., Тастанов Е.А.
- [15] Локшин Э.П., Иваненко В.И., Тареева О.А., Корнейко Р.И. Извлечение лантаноидов из фосфорнокислых растворов с использованием сорбционных методов // Журнал прикладной химии. 2009. Т.82. №4. С.544-551.
- [16] Михайличенко А.И., Папкина М.В., Конькова Т.В., Туманов В.В. Сорбционное извлечение РЗЭ из растворов фосфорной кислоты. М., 2014. С.51-55.
- [17] Косынкин В.Д., Селивановский Т.Т., Смирнов К.М., Крылова О.К. Комплексная переработка фосфогипса с получением химически осажденного мела, гипса и концентрата редкоземельных элементов // Цветные металлы. 2012. №3. С.31-34.
- [18] Патент 24889 РК. Способ извлечения редкоземельных элементов из маточных растворов уранового производства / Суркова Т.Ю., Мукушева А.С., Юлусов С.Б., Дуленин А.П., Гуцин А.П., Барменшинова М.Б. Опубл. 15.12.2014. Бюл. №12.
- [19] Patent 10155791 DE. Process for electrochemical decomposition of superalloys / Stoller Viktor et al. 2003.
- [20] Чернышева О.В., Дробот Д.В. Варианты электрохимической переработки ренийсодержащего жаропрочного сплава // Химическая технология. 2017. Том 18. №1. С. 36-42.
- [21] Агапова Л.Я., Абишева З.С., Килибаева С.К., Яхияева Ж.Е. Электрохимическая переработка техногенных отходов ренийсодержащих жаропрочных никелевых сплавов в сернокислых растворах // Цветные металлы. 2017. №10. С. 56-61.
- [22] Kenzhaliev B.K., Kyvatkovsky S. A., Kozhakhmetov S. M., Sokolovskaya L. V., Semenova A. S. (2018). Depletion of waste slag of balkhash copper smelter. Kompleksnoe Ispol'zovanie Mineral'nogo syr'â (Complex Use of Mineral Resources). 306 (3), 45–53. <https://doi.org/10.31643/2018/6445.16>
- [23] Загородняя А.Н. Шлам сернокислотного цеха балхашского медеплавильного завода – альтернативный источник получения селена на предприятии // Комплексное использование минерального сырья. – 2018. – №4. – С. 46-55. <https://doi.org/10.31643/2018/6445.29> <https://doi.org/10.31643/2018/6445.29>
- [24] ГОСТ 10298-79. Селен технический. Технические условия (с Изменениями N 1-5). No.4. 2004. <http://docs.cntd.ru/document/gost-10298-79>
- [25] Кенжалиев Б.К., Требухов С.А., Володин В.Н., Требухов А.А., Тулеутай Ф.Х. Извлечение селена из промпродуктов металлургического производства // Комплексное использование минерального сырья. – 2018. – №4. – С. 56-64. <https://doi.org/10.31643/2018/6445.30>
- [26] Rulyov N., Tussupbayev N., Turusbekov D., Semushkina L., Kaldybayeva Z. Effect of microbubbles as flotation carriers on finesulphide ore beneficiation // Mineral Processing and Extractive Metallurgy. - 2018. - Vol.127. - N.3. - Pp.133–139. <https://doi.org/10.1080/03719553.2017.1351067>
- [27] Абдылдаев Н. Н., Койжанова А. К., Камалов Э. М., Жанабай Ж. Д., Акчулакова С. Т. Доизвлечение золота в концентрат из лежалых хвостов методом флотации // Комплексное использование минерального сырья. – 2018. – №4. – С. 11-16. <https://doi.org/10.31643/2018/6445.25>
- [28] Erdenova M., Kenzhaliyev B., Koizhanova A., Temirova S., Abdyl daev N. Extraction of gold from man-made mineral raw materials by Methods of flotation enrichment and cyaning // 18th International Multidisciplinary Scientific GeoConference SGEM2018, Science and Technologies in Geology, Exploration and Mining. <https://doi.org/10.5593/sgem2018/1.4/s04.009>
- [29] Кенжалиев Б. К., Кульдеев Е.И., Абдулвалиев Р.А., Позмогов В.А., Бейсембекова, К.О., Гладышев С.В., Тастанов Е.А. Перспективы развития алюминиевой отрасли Казахстана // Известия НАН РК Серия геологии и технических наук. 2017. № 3. С.151-160.
- [30] Патент РК № 30113. Способ переработки низкокачественных железистых бокситов по Байер-гидрогранатовой технологии. // Абдулвалиев Р.А., Гладышев С.В., Тастанов Е.А.; опубл.15.08.2016.
- [31] Патент РК №33499. Способ переработки красного шлама / Кенжалиев Б.К., Ахмадиева Н.К., Абдулвалиев Р.А., Гладышев С.В., Омарова С.А., Манапова А.И., Зиновьева Л.В. от 07.03.2019. Бюл. №10.
- [32] Гладышев С.В., Абдулвалиев Р.А., Кенжалиев Б.К. и др. Разработка технологии получения хромитового концентрата из шламовых хвостов обогащения // Комплексное использование минерального сырья - 2018. - № 1. - С.12-17. <https://doi.org/10.31643/2018/166445>

- [33] Дюсенова С.Б., Кенжалиев Б.К., Абдулвалиев Р.А., Гладышев С.В. Комплексная гидрохимическая переработка шламовых хвостов обогащения хромитсодержащих руд // Обогащение руд. - № 6. - 2018. - С.27-32.
- [34] Позмогов В.А., Кульдеев Е.И., Дорофеев Д.В., Имангалиева Л.М., Квятковская М.Л. Определение физико-химических свойств и фазового состава железистых песков глиноземного производства для изыскания путей их дальнейшей переработки // Комплексное использование минерального сырья. - 2018. - № 3. - С. 69-77. <https://doi.org/10.31643/2018/6445.19>
- [35] Lokhova N.G, Naimanbaev M.A, Baltabekova Zh. A., Kasymzhanov K. K. (2018). Sorption rerecovery and concentration of rare-earth metals from extraction phosphoric acid. Review. Kompleksnoe Ispol'zovanie Mineral'nogo syr'a. 306(3), 62–68. <https://doi.org/10.31643/2018/6445.18>
- [36] Кенжалиев Б.К., Есимова Д.М., Суркова Т.Ю., Аманжолова Л.У., Акчулакова С.Т. Подготовка продуктивных растворов для извлечения редкоземельных элементов // Вестник КазННТУ.- 2018. - № 5. - С.367-373.
- [37] Патент РК №33153 Способ извлечения редкоземельных элементов из кремнистого сырья / Кенжалиева Б.К., Суркова Т.Ю., Юлусов С.Б., Пирматов Е.А., Дуленин А.П. от 01.10.2018
- [38] Агапова Л.Я., Кенжалиев Б.К., Абишева З.С., Килибаева С.К., Яхияева Ж.Е., Альтенова А.Н., Рузахунова Г.С. Получение никель-кобальтового концентрата из отходов жаропрочных никелевых сплавов // Труды Кольского научного центра РАН. Химия и материаловедение. - 2018. - №2 1/2018 (9), гл.2. - с. 798 - 803.
- [39] Паничкин А.В., Мамаева А.А., Дербисалин А.М., Кенжегулов А.К., Имбарова А.Т. Влияние состава наносимых на поверхность пленок твердых растворов на характеристики водородопроницаемых мембран из ниобия и тантала // Комплексное использование минерального сырья. – 2018. – №4. – С. 130-139. 121-129. <https://doi.org/10.31643/2018/6445.39>
- [40] Mamaeva, A. A., Kenzhegulov, A. K., & Panichkin, A. V. (2018). A Study of the Influence of Thermal Treatment on Hydroxyapatite Coating. Protection of Metals and Physical Chemistry of Surfaces, 54(3), 448–452. <https://doi.org/10.1134/s2070205118030115>